



# OPTOKON and LEMO SOLUTION

for broadcast & audio/video applications



## Content:

OPTOKON and LEMO cooperation and development.....	5
Broadcast & audio/video applications .....	6
OPTOKON solution for LEMO broadcast & audio/video .....	8
<b>OPK-SPCC0020-2(2x1.6)N9AHEWU .....</b>	<b>10</b>
<b>PUW - FUW Patchcord (cable).....</b>	<b>13</b>
<b>Cable Drums.....</b>	<b>15</b>
<b>FXW + EDW Patchcords .....</b>	<b>17</b>
<b>WST.ST - Splice Tray.....</b>	<b>19</b>
<b>WST.HT – Compact Splice Tray.....</b>	<b>21</b>
<b>FOH - Hybrid Splice Box.....</b>	<b>24</b>
<b>WST.TE.HDTV .....</b>	<b>26</b>
<b>OFT-850 .....</b>	<b>28</b>
<b>LMC-01.GM .....</b>	<b>30</b>





LEMO is the acknowledged leader in the design and manufacture of precision custom connection and cable solutions. LEMO's high quality Push-Pull connectors are found in a variety of challenging application environments including medical, industrial

control, test and measurement, audio-video and telecommunications.

LEMO has been designing precision connectors for seven decades. Offering more than 75,000 combinations of product that continue to grow through custom specific designs, LEMO and its affiliated sister companies REDEL, NORTHWIRE and COELVER currently serve more than 100,000 customers in over 80 countries around the world.



OPTOKON a.s. is a leading global producer and supplier of premium active and passive fiber optic components specializing in fully tested integrated data network, FTTx, and tactical military solutions. Our components and solutions can be found in applications in businesses, communities, and armed forces throughout the world.

OPTOKON, an ISO 9001 and EMS ISO 14 001 certified company, was founded in 1991 and is headquartered in the Czech Republic

In May 2020, OPTOKON signed a Cisco Solution Technology Integrator Agreement meaning that the company is entitled to 'design in' Cisco products and software into OPTOKON solutions. OPTOKON is also a Select Certified Partner of Cisco with Express Specialization.

The operational management structure of the OPTOKON Group is based on a matrix organization consisting of six manufacturing divisions utilizing state-of-the-art technology and strong technical expertise to create the OPTOKON product portfolio. This is coupled with regionally managed OPTOKON facilities comprised of company branches and distribution outlets thus ensuring an active global distribution network to meet customer demand.

## OPTOKON and LEMO cooperation and development



LEMO connectors have become a go-to choice for high-quality electrical connectors in a variety of industries. One such industry is the fiber optic market, where LEMO has partnered with OPTOKON, a leading fiber optic company, to develop specialized products for their customers.

### **OPTOKON is certified to assemble connectors and cables for LEMO.**

Thanks to this partnership, LEMO offers a range of specialized products that are exclusive to their collaboration with OPTOKON. These products include FXW + EDW Patchcords, Internal Breakout Cables with LEMO SMPTE Connectors, a 2U Rack mounted splice panel with FXW 3K.93C plug, a 2U Half Rack module that can carry up to 3 SMPTE connectors (18 cm depth), and FOH - Hybrid Splice Box Splicing and termination, Power connectors for LEMO 3K.93C.

One standout product from this collaboration is the SMPTE Hybrid cable checker. This innovative product is designed to quickly and easily check the integrity of SMPTE hybrid cables, ensuring that they are functioning correctly and ready for use.

Partnership between LEMO and OPTOKON has resulted in the development of high-quality, specialized products that are designed to meet the specific needs of their customers in the fiber optic market.



### **WST.ST - Splice Tray**

**2U Rack mounted splice panel with FXW 3K.93C plug  
EXCLUSIVELY DEVELOPED FOR LEMO**



## Broadcast & audio/video applications

LEMO connectors, particularly those with SMPTE fiber optic interfaces, are widely used in the broadcast industry for their reliability and precision. They are a popular choice for a range of applications, including high-definition video and audio transmission, as well as power and data transmission.

In broadcast applications, LEMO connectors are typically used to connect various pieces of equipment, such as cameras, monitors, and control systems. These connectors provide a secure and stable connection, ensuring that high-quality signals are transmitted without interference or loss of signal.

One common use of LEMO connectors in the broadcast industry is for fiber optic camera connections. Broadcast cameras often use SMPTE fiber optic connections to transmit video signals over long distances. LEMO connectors with SMPTE interfaces are ideal for this purpose, as they provide a secure and stable connection, even in harsh environments.

LEMO connectors are also widely used for power and data transmission in broadcast applications. For example, they may be used to connect remote control units or to power peripheral devices, such as monitors and lighting equipment.



**WST.HT – Compact Splice Tray**  
2U Half Rack module to carry up to 3 SMPTE connectors (18 cm depth)  
**EXCLUSIVELY DEVELOPED FOR LEMO**

## Broadcast & audio/video applications

OPTOKON providing complete connectivity solutions for LEMO broadcast industry connectors.

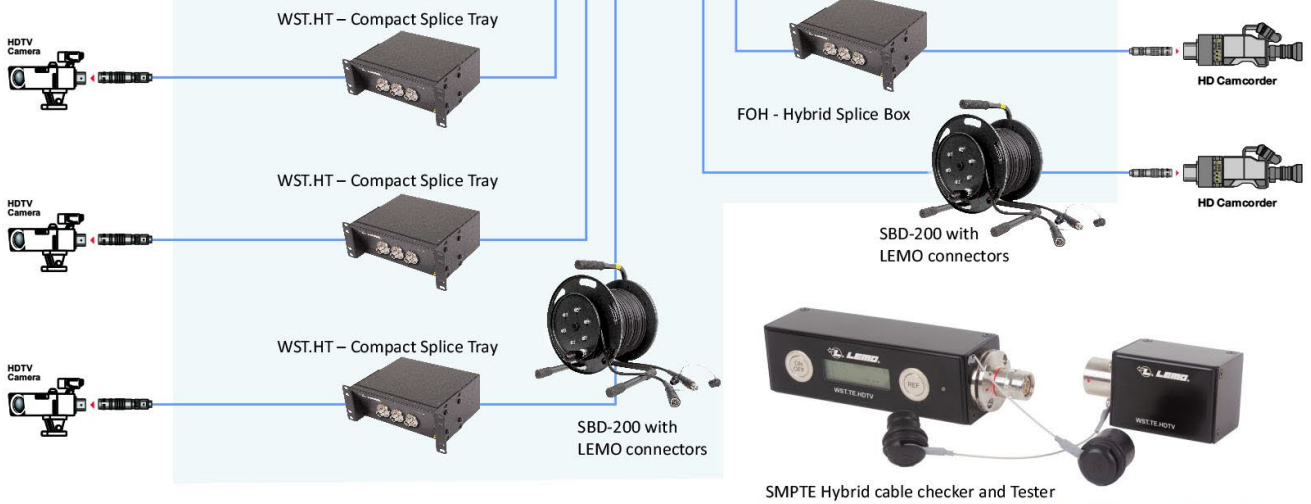

OFT-850 SMPTE Hybrid Cable Test Set



## OPTOKON solution for LEMO broadcast & audio/video

### PUW - FUW Patchcord (cable)

SMPTE LEMO FUW Male Plug to PUW Female Socket

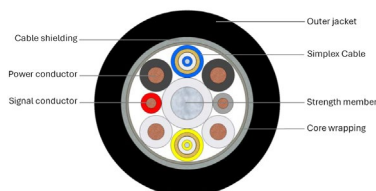

Hybrid copper/fiber cable for applications where there is a requirement for data communication by fiber optic and at the same time is needed power supply. Suitable for FTTA applications, CCTV systems.



LEMO SMPTE Fiber Optic HDTV Interconnection Cable Assembly. The cable consists of four main cores, two signal lines, two fixed cores, a tinned copper braid and a flexible PUR sheath. It is equipped with a LEMO FUW plug and a LEMO PUW socket. The cable is suitable for transmitting audio and video signals over long distances and for supplying power to system cameras.

### Cable Drums



OPTOKON offers complimentary high quality deployable cable drums. Users can select the appropriate design and style for their particular application. The drums are ideally suited to Military, Industrial, Broadcast and pro Audio applications. All drums are supplied with a third flange allowing full access to each end of the cable assembly.

The drums are delivered in standard black color RAL 9005 mat. Other - green khaki RAL 6014 mat color is available upon request<sup>1</sup>.

### FXW + EDW Patchcords

Internal Breakout Cables with LEMO SMPTE Connectors



LEMO's Internal Breakout Cables split duplex SC or LC fiber optics and have SMPTE connectors. They're mountable on blank panels or can replace hybrid devices. They come in FXW or EDW models with a power option and are suitable for use with WST.ST-Splice trays, rack panels, and wall boxes.

### **WST.ST - Splice Tray**

2U Rack mounted splice panel with FXW 3K.93C plug  
EXCLUSIVELY DEVELOPED FOR LEMO



WST.ST-Splice Tray is a space-saving HD video bulkhead interface solution for mobile production and studios. Its modular design allows for easy configuration, accommodating up to eight SMPTE 311M hybrid fiber camera cables/LEMO 3K.93C SMPTE 304M bulkhead connector interfaces. It's field-terminable with a portable automatic fusion splicer, making it suitable for projects with application constraints.

### **WST.HT – Compact Splice Tray**

2U Half Rack module to carry up to 3 SMPTE connectors (18 cm depth)  
EXCLUSIVELY DEVELOPED FOR LEMO



WST.HT-Compact Splice Tray is a modular, space-saving HD video bulkhead interface for mobile production and studios. The 2U Half Rack cabinet holds up to four SMPTE 311M hybrid fiber camera cables/LEMO 3K.93C SMPTE 304M bulkhead connector interfaces. It's field-terminable with a portable automatic fusion splicer for projects with application constraints.

### **FOH - Hybrid Splice Box**

Splicing and termination, Power connectors for LEMO 3K.93C  
EXCLUSIVELY DEVELOPED FOR LEMO



FOH-Hybrid Splice Box is a compact indoor cabinet for splicing and storage of up to 4 LEMO 3K.93C Pigtail connectors with 4 power connectors MATE-N-LOK. It's modular and ideal for broadcast infrastructure inside wall boxes and patch panels, fitting cabinets with minimum depth of 15 cm. It supports various types of optical adapters.

### **WST.TE.HDTV**

SMPTE Hybrid cable checker  
EXCLUSIVELY DEVELOPED FOR LEMO



The WST HYBRID CABLE CHECKER includes an SMPTE measuring unit and an SMPTE loopback for testing optical power level and copper pair continuity in hybrid cables. It combines an optical light source, detector, and copper wire checker. The compact unit is ideal for testing the LEMO SMPTE Hybrid System and has a rugged aluminum case for field use with a rechargeable lithium battery.

### OFT-850 SMPTE Hybrid Cable Test Set



The OFT-850 set includes an SMPTE SOURCE and TESTER unit for testing optical fiber loss and copper pair continuity in hybrid cables. It features an optical light source, power meter, and copper wire checker, and is suitable for testing large spaces of the LEMO SMPTE Hybrid System. Its ruggedized aluminum case makes it ideal for field use, and it can store over 1000 measurements. The tester supports memory download and report generation, and its Lithium rechargeable battery offers long-term operation with minimal costs.

### CS-SFP - Gigabit SFP Media Converter



The LMC-01.GM offers the media converter housed in a metal box. It provides LEMO FXW 3K.93C connectors for fiber optic cable and copper twisted pairs ports for harsh environmental conditions. The LMC-01.GM 10/100/1000 Mbps adaptive Gigabit Ethernet media converter adopts switching technology to fulfill media conversion. It complies with IEEE802.3, IEEE802.3u, IEEE802.3z and IEEE802.3ab standards.



Cerve  
20 56



## OPK-SPCC0020-2(2x1.6)N9AHEWU

### Description:

Hybrid copper/fiber cable for applications where there is a requirement for data communication by fiber optic and at the same time is needed power supply. Suitable for FTTA applications, CCTV systems.

### Features:

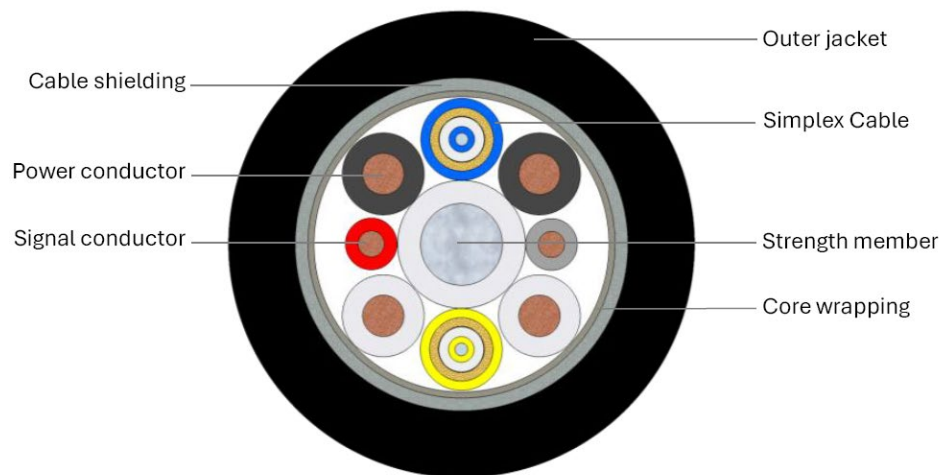

### Specifications:

Fibre count	2	
Fibre Type	G.657.A1, G 657.A2	
Fibre colour	Blue, Yellow	
Buffer diameter	0.9 mm	
Buffer material	PA12 (Nylon)	
Buffers colour	Natural-transparent	
Simplex colour	Blue, Yellow	
Simplex jacket	Halogen-free flame-retardant thermoplastic compound	
Simplex diameter	1.6 mm	
Power conductor Count	4	
Power conductor Colour	Black (2x), White (2x)	
Power conductor type	Stranded Tinned Copper, AWG 20 (19x0.2 mm)	Insulation material HDPE
Power conductor diameter	1.6 mm	
Signal conductor Count	2	
Signal conductor Colour	Grey, Red	
Signal conductor type	Stranded Tinned Copper, AWG 24 (7x0.2 mm)	Insulation material HDPE
Signal conductor diameter	1.1 mm	
Central strength member	Zn plated steel wire, coated FR-LSHF	Core wrapping Water-swellaable tape
Shield	Tinned copper wire braiding, covering density min. 95%	
Outer jacket	UV stable Flame-retardant TPU	Outer Jacket
Outer jacket colour	Black	
Outer jacket thickness	1.3 mm	
Nominal outer diameter	9.1 mm	
Cable Weight (calc.)	119 kg/km	

**Ordering code:**

OPK-SPCC0020-2(2x1.6)N9AHEWU-xx-BK xx – fiber type (see Cable code datasheet)

Delivery length 1000 m±5% on plywood reel

Print legend OPTOKON KABLE CFN.3K.93C.092UNCS SMPTE 311 SINGLE-MODE HYBRID HDTV LSZH CABLE  
300V ROHS2 COMPLIANT JOB NO. xxxxM

Max. Loading (Short Term)	800 N	EN 60794-1-21-E1
Max. compressive loading	2000 N/10cm]	EN 60794-1-21-E3
Max. Impact loading	10 Nm	EN 60794-1-21-E4
Min. bend radius not load	10 x OD	EN 60794-1-21-E11
Min. bend radius load	15 x OD	EN 60794-1-21-E11
Operating temperature range	-40 to +75°C	EN 60794-1-22-F1
Storage temperature range	-40 to +75°C	EN 60794-1-22-F1
Water tightness	No water detected	on free end
Class of fire reaction	Fca	

## Power conductor

Resistance	≤35.3 Ω/km @ 20°C
Insulation resistance	≥10 000 MΩ•km @ 20°C Test
Voltage	1750 V / AC <sub>eff</sub>
Operating Voltage	600 V / AC <sub>eff</sub>

## Signal conductor

Resistance	≤97.5 Ω/km @ 20°C
Insulation resistance	≥10 000 MΩ•km @ 20°C Test
Voltage	1750 V / AC <sub>eff</sub>
Operating Voltage	300 V / AC <sub>eff</sub>

# PUW - FUW Patchcord (cable)

## SMPTE LEMO FUW Male Plug to PUW Female Socket

### Description:

LEMO SMPTE Fiber Optic HDTV Interconnection Cable Assembly. The cable consists of four main cores, two signal lines, two fixed cores, a tinned copper braid and a flexible PUR sheath. It is equipped with a LEMO FUW plug and a LEMO PUW socket. The cable is suitable for transmitting audio and video signals over long distances and for supplying power to system cameras.



### Features:

- Features top-quality LEMO connectors with a protective elastomer sleeve for added durability
- Can be used with high-end broadcast cameras made by SONY, JVC, Panasonic, Grass Valley, and the Blackmagic Fiber Converter
- Includes four copper lines (2 for power and 2 for remote control)
- Utilizes the HD camera cable CAM311, which has a tough PUR outer jacket that makes it ideal for use in mobile outdoor settings
- Consists of two Single-Mode optical fibers with E9/125 μm diameter that meet the ITU G.657.A standard
- Comes with a central steel strength member that provides strain relief for added protection
- Compliant with the SMPTE-311M and SMPTE-304M standards

LEMO's 3K.93C SMPTE Fiber HDTV connectors are the standard in national and international broadcast companies. Fast transition to HDTV transmission is easier than ever with LEMO.

It supports 19.4 Mbps to 3 Gbps bandwidths.

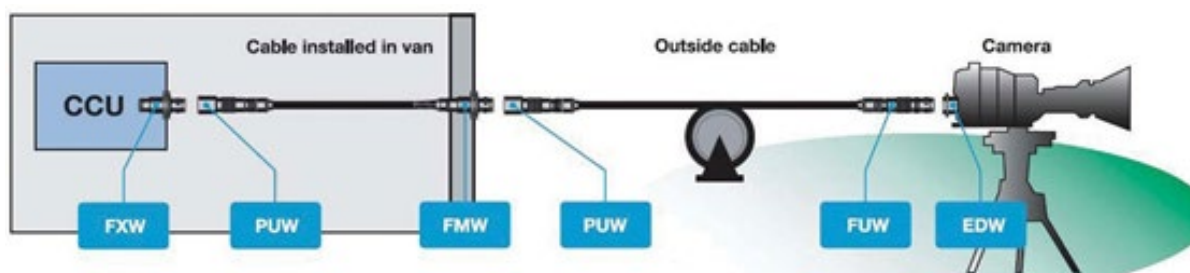

### Basic parts of patchcord:

<b>Cable typ</b>	SMPTE standard cable 311M-1998 (ARIB BTA S 1005B)
<b>Connector 1</b>	Camera cable socket SMPTE304M (PUW) / LEMO
<b>Connector 2</b>	Camera cable plug SMPTE304M (FUW) / LEMO

**Ordering code:**

<b>PUW</b>		-	<b>FUW</b>		-	<b>311M</b>		-	<b>XXX<sup>1</sup></b>	
<b>Type of LEMO connectors</b>					<b>Type of cable</b>			<b>XXX - Length [m]</b>		
<b>PUW</b>	Socket LEMO connector									
<b>FUW</b>	Plug LEMO connector									

Note: 1) **XXX** Examples of length: 005 → 5 meters  
100 → 100 meters

**Details of connectors:**



**PUW** SMPTE Hybrid connector 3K.93C



**FUW** SMPTE Hybrid connector 3K.93C

**LEMO 3K.93C Series Connectors:**

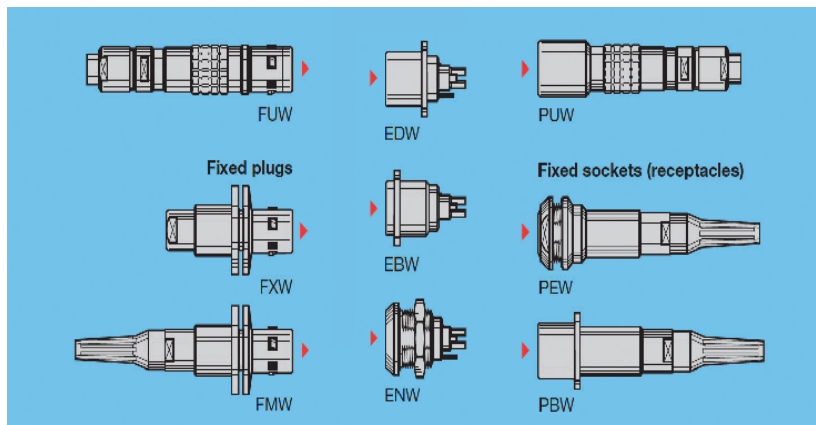





**PUW-FUW-311M-005**

## Cable Drums

### Description:

OPTOKON offers complimentary high quality deployable cable drums. Users can select the appropriate design and style for their particular application. The drums are ideally suited to Military, Industrial, Broadcast and pro Audio applications. All drums are supplied with a third flange allowing full access to each end of the cable assembly.

The drums are delivered in standard black color RAL 9005 mat. Other - green khaki RAL 6014 mat color is available upon request<sup>1</sup>.

<p><b>BBD-500NR, BBD-1000, BBD-1500N</b> -(6014<sup>1</sup>)</p> <p>Heavy duty drum with direct crank rewind permanently attached to the axle. Designed for installation on military vehicle or TBD-500 type trolley suitable for mobile applications.</p>	 <p>BBD-1000</p>
<p><b>TBD-500NR</b> -(6014<sup>1</sup>)</p> <p>Trolley drum with one-piece foot, rubber tyres and removable steel handlebars for long term shipping and storage. Large wheel diameter allows easy field operations.</p>	 <p>BBD-500NR      TBD-500NR-6014</p>
<p><b>SBD-200</b> -(6014<sup>1</sup>)</p> <p>Small, lightweight and durable design for quick and easy use, ideal for applications where 200 m lengths of cable are deployed out over large areas.</p>	 <p>SBD-200-with LEMO connectors</p>
<p><b>MBD-200, MBD-500</b> -(6014<sup>1</sup>)</p> <p>These reels are stackable for maximum transport and storage efficiency, rugged steel construction throughout, including square tubular frame.</p>	 <p>MBD-500</p>
<p><b>RBD-200, RBD-500</b> -(6014<sup>1</sup>)</p> <p>Mobile drum, with strap belts for shoulder wear. Suitable for use in the field. Weight with HMA connectors 200 m cable is 15 kg. The drum is available in two versions, for 200 m and 500 m of 5.5 mm tactical cable.</p>	 <p>RBD-200-6014      RBD-500</p>

**BBD-500NR, BBD-1000, BBD-1500N**

The drum BBD-500NR is designed for winding of up to 500 m cable diameter 5.5 mm. Type BBD-1000/1500N is wider and allows storage up to 1/1.5 km cable diameter 5.5 mm.

Weight:

BBD-500NR:11.4 kg, BBD-1000:13.3 kg, BBD-1500N:15.5 kg

Reel Dimensions BBD-500NR, BBD-1000/1500N (mm)

A	B	C	D	E	F	G	H
360	210	140	330	410	480	490	280
600	450	140	330	410	690	490	280
780	630	140	330	410	890	490	280

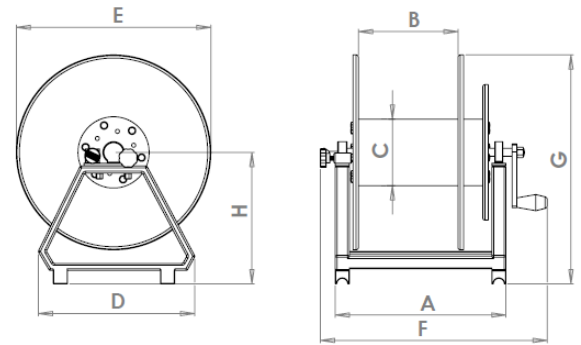

**TBD-500NR**

The BBD drum is installed on a mobile chassis.

Weight: TBD-500NR: 23 kg

Reel Dimensions TBD-500NR (mm)

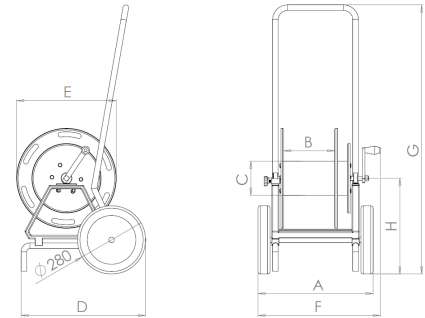
A	B	C	D	E	F	G	H
470	210	140	510	410	500	1090	390



**SBD-200**

For a typical cable diameter of 5.5 mm, the SBD drum will accept 250 m of cable.

Weight: SBD-200: 6.2 kg

Reel Dimensions SBD-200 (mm)

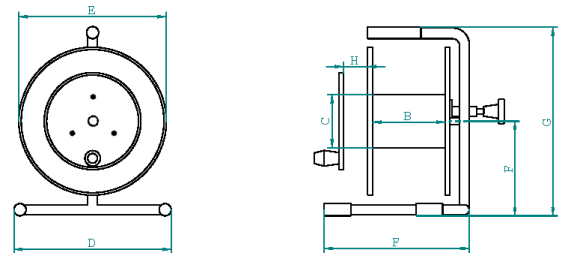
B	C	D	E	F	G	H
200	110	325	305	300	390	30

**MBD-200, MBD-500**

Two different drums dimensions.

The MBD-200 drum will accept 200 m, the MBD-500 up to 500 m cable of 5.5 mm diameter.

Weight: MBD-200: 8.0 kg, MBD-500: 10.8 kg

Reel Dimensions MBD-200, MBD-500 (mm)

A	B	C	D	E	F	G	H
290	200	110	375	305	385	370	185
340	210	140	465	410	420	470	235

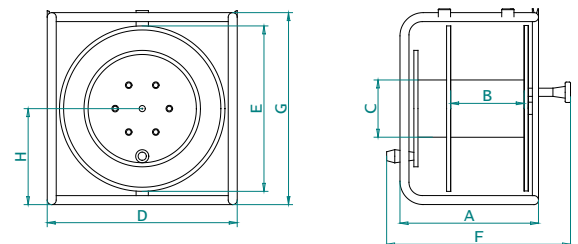

**RBD-200, RBD-500**

For a typical cable diameter of 5.5 mm, the RBD drum will accept 200 m, the RBD-500 up to 500 m of cable.

Weight: RBD-200: 9.7 kg, RBD-500: 10.7 kg

Reel Dimensions RBD-200, RBD-500 (mm)

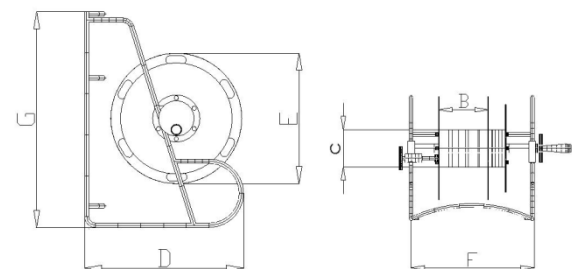
A	B	C	D	E	F	G	H
-	200	110	310	305	360	570	-
-	325	110	320	305	430	570	-



Note: 1) Standard black color RAL 9005 mat, use code -6014 if green khaki RAL 6014 mat color is required.  
2) Dimensions tolerance:  $\pm 20$  mm

## FXW + EDW Patchcords

### Internal Breakout Cables with LEMO SMPTE Connectors

#### Description:

The Internal Breakout Cables are made with LEMO SMPTE connectors and are designed to split duplex SC, or LC fiber optics. These cables can be mounted on blank panels or used as replacements in hybrid devices. You can choose between Fixed Plug (**FXW**) or Fixed Socket (**EDW**) models, with power option. These patchcords are suitable for use in WST.ST-Splice trays, rack panels and wall boxes.

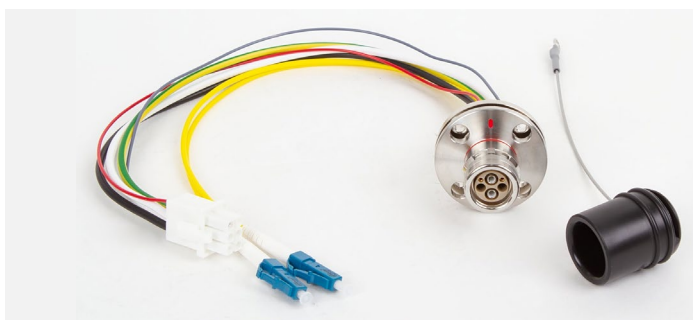

*Breakout cable-patchcord with SMPTE311 LEMO 3K.93C **FXW**, two single LC connectors and 6 way electrical plug terminated tails in MATE-N-LOK connector, 30cm length*

Ordering code:  
**FXW-2xULC-20 S2D-M-0.3**

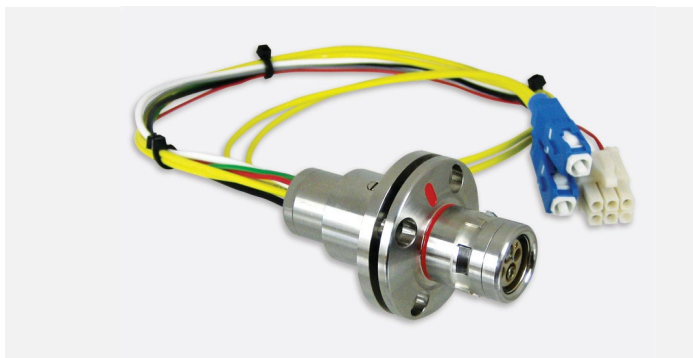

*Breakout cable-patchcord with SMPTE311 LEMO 3K.93C **FXW**, two single SC connectors and 6 way electrical plug terminated tails in MATE-N-LOK connector, 30cm length*

Ordering code:  
**FXW-2xUSC-20 S2D-M-0.3**

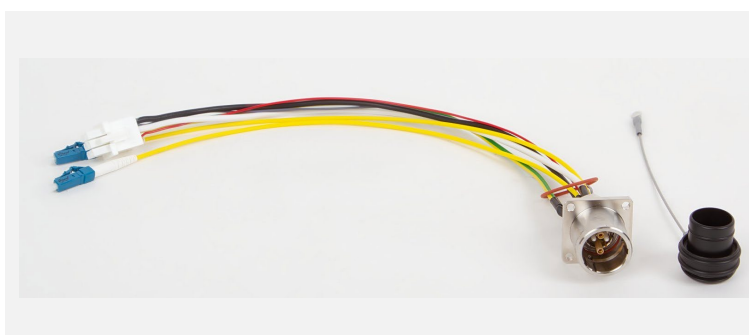

*Breakout cable-patchcord with SMPTE311 LEMO 3K.93C **EDW**, two single LC connectors and 6 way electrical plug terminated tails in MATE-N-LOK connector, 30cm length*

Ordering code:  
**EDW-2xULC-20 S2D-M-0.3**

Lemo 3K.93C stainless steel connectors **FXW** and **EDW** use the dependable LEMO push-pull latching system and can handle up to 20,000 mating cycles. With proper maintenance and cleaning, the fiber contacts can also withstand this level of endurance.

**Ordering code:**

<b>AAA</b>	-	<b>x-20 S2D</b>	-	<b>M</b>	-	<b>XXX</b>							
<b>AAA - Type of LEMO connector</b> <table border="1"> <thead> <tr> <th>Type</th> <th>Description</th> </tr> </thead> <tbody> <tr> <td>FXW</td> <td>FXW LEMO connector</td> </tr> <tr> <td>EDW</td> <td>EDW LEMO connector</td> </tr> </tbody> </table>		Type	Description	FXW	FXW LEMO connector	EDW	EDW LEMO connector			<table border="1"> <thead> <tr> <th>XXX - Length [m]</th> </tr> </thead> <tbody> <tr> <td>0.3 30 cm</td> </tr> </tbody> </table>		XXX - Length [m]	0.3 30 cm
Type	Description												
FXW	FXW LEMO connector												
EDW	EDW LEMO connector												
XXX - Length [m]													
0.3 30 cm													
				<table border="1"> <thead> <tr> <th>M - MATE-N-LOK (AMP) plug connector</th> </tr> </thead> <tbody> <tr> <td></td> </tr> </tbody> </table>			M - MATE-N-LOK (AMP) plug connector						
M - MATE-N-LOK (AMP) plug connector													
<table border="1"> <thead> <tr> <th>x - Type of optical connector</th> <th>Info about Type of fiber</th> </tr> </thead> <tbody> <tr> <td>2xULC 2x LC single connector</td> <td>Cable Ø 2.0 mm</td> </tr> <tr> <td>2xUSC 2x single SC connector</td> <td>SM 9/125 µm (G.652D)</td> </tr> </tbody> </table>			x - Type of optical connector	Info about Type of fiber	2xULC 2x LC single connector	Cable Ø 2.0 mm	2xUSC 2x single SC connector	SM 9/125 µm (G.652D)					
x - Type of optical connector	Info about Type of fiber												
2xULC 2x LC single connector	Cable Ø 2.0 mm												
2xUSC 2x single SC connector	SM 9/125 µm (G.652D)												

**FXW.3K**

1	BLU	Fiber-optic	BLU	1
2	YEL	Fiber-optic	YEL	2
3	GRY	Control	GRY	3
4	RED	Control	RED	4
5	BLK	Power line	BLK	5
6	BLK	Power line	BLK	6
	WHT	Power line	WHT	
	WHT	Power line	WHT	

**EDW.3K**

1	BLU	Fiber-optic	BLU	1
2	YEL	Fiber-optic	YEL	2
3	GRY	Control	GRY	3
4	RED	Control	RED	4
5	BLK	Power line	BLK	5
6	BLK	Power line	BLK	6
	WHT	Power line	WHT	
	WHT	Power line	WHT	

MATE-N-LOK plug

*Standard termination of SMPTE311 FXW 3K.93C and EDW 3K.93C*

**Example of using - 2U Rack mounted Splice Tray:**

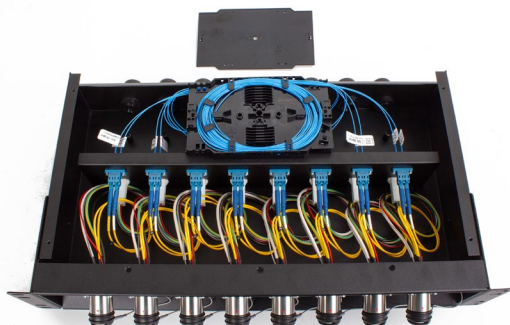

*Internal arrangement of WST.ST.X0D8*



*Front view of WST.ST.X0D8*

*Note: Details about Splice Tray are in datasheet CMS\_01-21\_EN-WST.ST-Splice tray.pdf*

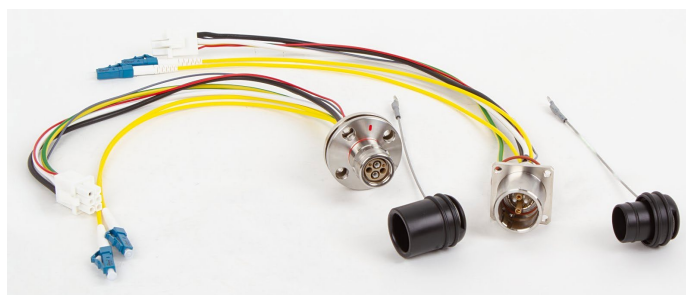

## WST.ST - Splice Tray

**2U Rack mounted splice panel with FXW 3K.93C plug**  
**EXCLUSIVELY DEVELOPED FOR LEMO**

### Description:

The new **WST.ST-Splice Tray** offers users the ability to quickly and easily install a space saving and robust HD video bulkhead interface solution without compromising performance.

Being modular by design, this versatile system can be easily configured to specific application requirements and therefore quick turn-around bespoke solutions can be easily supported.

With each system accommodating up to eight *SMPTE 311M* hybrid fibre (HD) camera cables / *LEMO 3K.93C SMPTE 304M* bulkhead connector interfaces, it is ideal for mobile production and studio applications. By means of a portable automatic fusion splicer it can be field terminated, making it suitable for projects where application constraints prohibit the use of pre-terminated camera cables.



*WST.ST.X0D8-DLCF-S-C2-8M*

### Key features:

- Compact, Aluminum ENAW-5754 material chassis design with easy internal access
- A configurable modular construction which accommodates up to **eight** LEMO EDW/FXW bulkhead connectors
- Designed for LEMO 3K.93C bulkhead connectors, factory terminated to internal LC fibre-optic and quick mate electrical connectors
- Inline internal breakout design providing uniform and optimized fiber bend radii across all terminals
- Design compatible with all standard **19"** **2U** racking systems
- Common off-the-shelf components and sub-assemblies enabling easy system upgrades and field servicing
- Tested and certified by original manufacturer of 3K.93C SMPTE 304M connectors

### Mechanical specifications:

PART NUMBER	Fibre connector type	DIMENSIONS (H x W x D) mm	WEIGHT (kg)
<b>WST.ST</b>	LC-duplex, SC, E2	88 x 483 x 250	2.5 kg

### Key benefits:

- Reduced application space requirements enabling simplified system level architecture
- Simplified installation process with integration being completed with basic fusion splicing and electrical crimping techniques
- Improved performance through factory terminated fibre-optic interface contacts and an optimised internal cable management system
- Reduced cost of ownership through higher product quality and improved protection levels
- Reduced manufacturing lead-times, as all solutions use common off-the-shelf component and subassemblies, configured to specific customer needs
- Reduced service costs through ease of access and reduced spares inventory requirements
- Reduced transport costs for overseas or mobile applications

### WST.ST - Product overview:



*Internal arrangement of WST.ST.X0D4-DLCF-S-C1-4M*

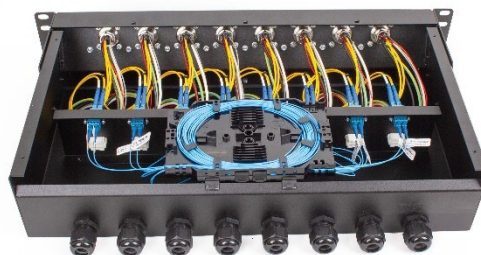

*Internal arrangement of WST.ST.X0D8 - Back view*

### Details of WST.ST cabinet:



*WST.ST.X0D8 – front view with EDW 3K.93C*

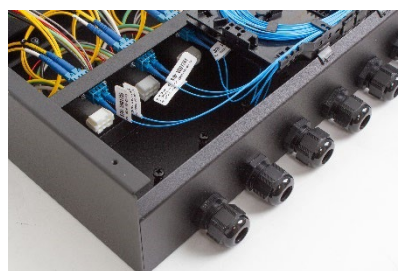

*WST.ST.X0D8 - Detail of cable holders, pigtails*

### Example of types LEMO connectors:



*FXW 3K.93C plug*



*EDW 3K.93C socket*

## WST.HT – Compact Splice Tray

**2U Half Rack module to carry up to 3 SMPTE connectors (18 cm depth)  
EXCLUSIVELY DEVELOPED FOR LEMO**

### Description:

The new **WST.HT-Compact Splice Tray** offers users the ability to quickly and easily install a space saving and robust HD video bulkhead interface solution without compromising performance.

Being modular by design, this versatile system can be easily configured to specific application requirements and therefore quick turn-around bespoke solutions can be easily supported.

The **WST.HT 2U Half Rack** cabinet uses a reduced depth of 18 cm while maintaining its full functionality.

With each system accommodating up to four *SMPTE 311M* hybrid fibre (HD) camera cables / *LEMO 3K.93C SMPTE 304M* bulkhead connector interfaces, it is ideal for mobile production and studio applications. By means of a portable automatic fusion splicer it can be field terminated, making it suitable for projects where application constraints prohibit the use of pre-terminated camera cables.



### Key features:

- Compact, aluminum-magnesium alloy ENAW-5754 material chassis design with easy internal access
- A configurable modular construction which accommodates up to **three** LEMO EDW/FXW bulkhead connectors
- Designed for LEMO 3K.93C bulkhead connectors, factory terminated to internal LC fibre-optic and quick mate electrical connectors
- Inline internal breakout design providing uniform and optimized fiber bend radii across all terminals
- Design is suitable for **2U 19" Half rack** systems
- Common off-the-shelf components and sub-assemblies enabling easy system upgrades and field servicing
- Tested and certified by original manufacturer of 3K.93C SMPTE 304M connectors
- Durable powder coat finish in **RAL 9005** colour (black)

### Mechanical specifications:

PART NUMBER	Fibre connector type	DIMENSIONS (H x W x D) mm	WEIGHT (kg)
WST.HT	LC-duplex, SC, E2	88 x 267* x 180	1.2 kg

\* With both unit holders

### Key benefits:

- Reduced application space requirements enabling simplified system level architecture

- Simplified installation process with integration being completed with basic fusion splicing and electrical crimping techniques
- Improved performance through factory terminated fibre-optic interface contacts and an optimised internal cable management system
- Reduced cost of ownership through higher product quality and improved protection levels
- Reduced manufacturing lead-times, as all solutions use common off-the-shelf component and subassemblies, configured to specific customer needs
- Reduced service costs through ease of access and reduced spares inventory requirements
- Reduced transport costs for overseas or mobile applications

**WST.HT - Product overview:**



*Front view of WST.HT.Z3*

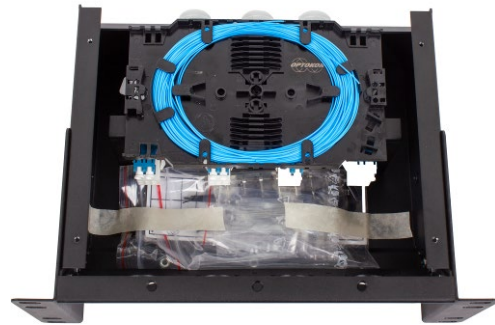

*Internal arrangement of WST.HT.Z3*

**Details of WST.HT:**



*WST.HT.Z3 – Detail of front panel*



*WST.HT - Detail of cable glands*

**Example of types SMPTE connectors:**



*FXW 3K.93C plug*



*EDW 3K.93C socket*

**Application overview:**

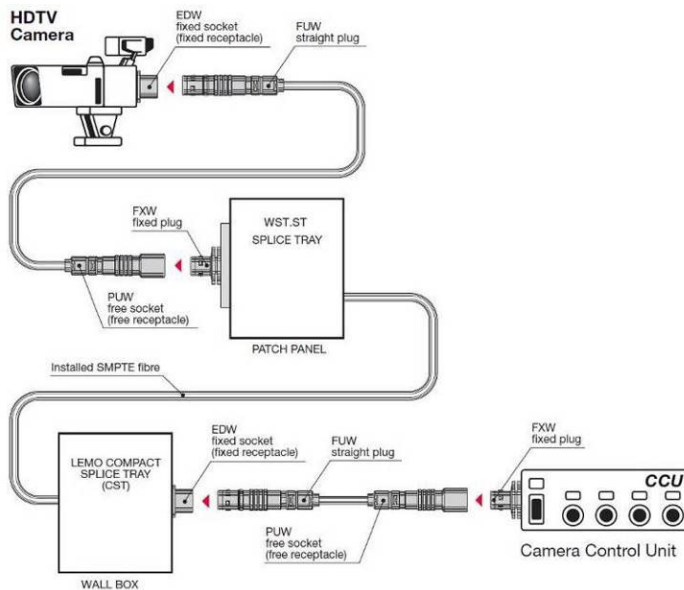

**Ordering code:**

**WST.HT.**      **Xx**      -      **XX(F)<sup>1</sup>-X**      -      **CX**      -      **XM**      -      **(xP)**

<p><b>Xx</b> - Numbers of <b>FXW connectors (0 - 3)</b>  <b>Zx</b> - Numbers of empty holes <b>without connectors (0 - 3)</b></p>	<p><b>XX(F)<sup>1</sup>-X</b></p>	<p><b>CX</b></p> <p><b>Splice trays 0 - 2</b></p>	<p><b>XM</b></p> <p><b>X</b> - Numbers of <b>MATE-N-LOK connectors</b></p>	<p><b>(xP)</b></p> <p><b>x</b> - Numbers of cable glands</p>
---	-----------------------------------	---	--	--

Coupling Type			
<b>DLC(F)</b>	Duplex LC	<b>M</b>	Multi mode
<b>SC(F)</b>	SC	<b>S</b>	Single mode
<b>E2(F)</b>	LSH (E2000)	<b>A</b>	APC mode

Note: 1) F - Fixed adaptors by screws

**Example of Ordering code:**

- WST.HT.X3 - Compact Splice Tray Half Rack loaded with 3 FXW connectors
- WST.HT.X2 - Compact Splice Tray Half Rack loaded with 2 FXW connectors
- WST.HT.Z3 - Compact Splice Tray Half Rack with 3 hole provision, no connectors loaded
- WST.HT.Z2 - Compact Splice Tray Half Rack with 2 hole provision, no connectors loaded

# FOH - Hybrid Splice Box

**Splicing and termination, Power connectors for LEMO 3K.93C  
EXCLUSIVELY DEVELOPED FOR LEMO**

## Description:

The **FOH-Hybrid Splice Box** is ideal wall mount interconnect indoor cabinet designed for splice, storage and protection up to 4 LEMO 3K.93C Pigtail connectors (using SC or DLC adaptors) and with 4 power connectors MATE-N-LOK (6 way). These compact, modular units are ideal for use in broadcast infrastructure network inside the wall boxes and patch panels. FOH designed with compact size which can fit for cabinets with minimum depth of 15 cm. The **FOH** allows to use different types of optical adapters (SC, LC, E2, etc).



## Features

- Modular system
- Small dimensions and low weight
- Craft friendly - protection for facility and user connections
- Easy wall mounting
- Easy exchangeable panel for most common optical connector types (SC, LC, E2, ...)
- Cable clamps inside for firm holding of hybrid cable
- Premium Aluminum material – ENAW-5005 H14
- Luxury Stainless Steel Look (SSL)

## Technical specifications

PART NUMBER	No. Of LEMO Connectors	DIMENSIONS (H x W x D) mm	SHIP WGT (kg)
FOH-x-xx-x-xM <sup>1</sup>	Up to 4	65 x 180 x 140	0.45 kg

<sup>1</sup> AMP Plastic Connectors MATE-N-LOK

## Product application:

Splicing and Termination of LEMO 3K.93C Hybrid Fiber Connectors.

## Examples of FOH products:



FOH-8-SCF-S-4M - front view



FOH-4-SCF-S-2M - front view

**Ordering code:**

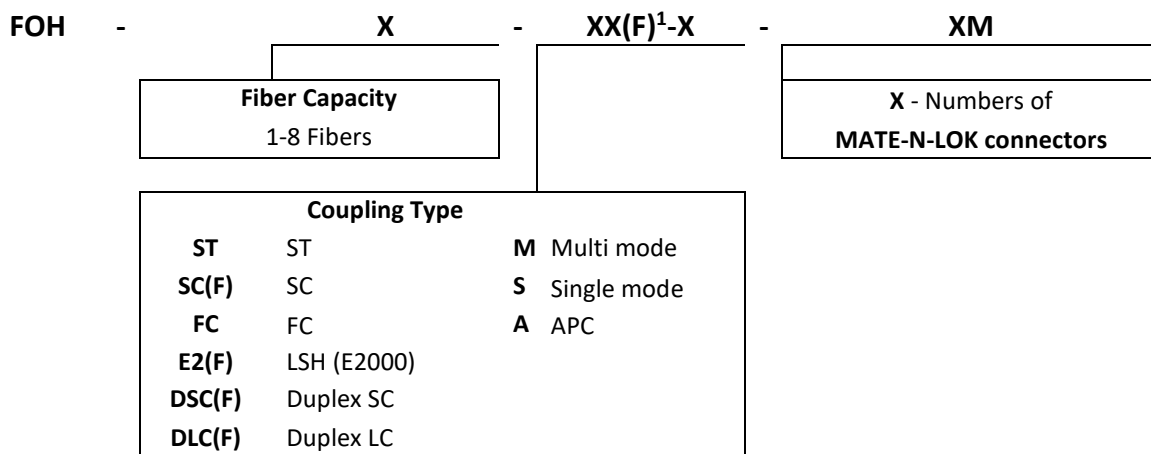

Note: 1) F - Fixed adaptors by screws

**Pictures of FOH hybrid splice box:**



FOH-2-SCF-S-1M - front view

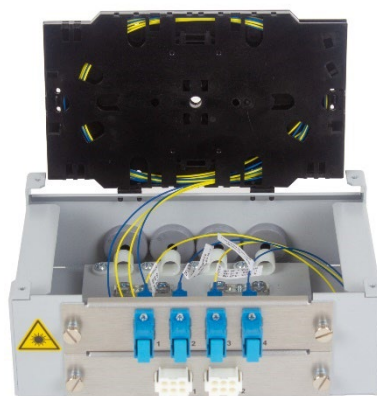

FOH-4-SCF-S-2M - Opened box

**EXAMPLE OF USING OF FOH-Hybrid Splice Box in LEMO:**

Sample LEMO 3K.93C FXW Pigtail\* which is using the FOH Splice Box for termination in the Wall Box, but preferred is the SC connectors:

**MXT** ECU side pigtails

Assembly cable with one fixed plug (FXW) and one pigtail (LC) complete with BHA cap.

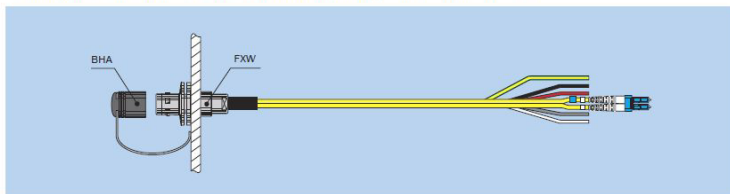

\* Pigtail FXW **MXT.3K.93C.ZZC050** using LEMO SMPTE Connector

# WST.TE.HDTV

## SMPTTE Hybrid cable checker EXCLUSIVELY DEVELOPED FOR LEMO

### Description:

The WST HYBRID CABLE CHECKER set consists of an SMPTE measuring unit and an SMPTE loopback. The hybrid cable checker is designed for testing optical power level in optical fibers and the continuity of copper pairs in hybrid cables. It combines an optical light source, optical detector, and copper wires checker. It is ideal for testing large spaces of the LEMO SMPTE Hybrid System for Broadcast Infrastructure Networks. The ruggedized aluminium case makes the unit ideal for field operation. The Lithium rechargeable battery ensures long term working with minimum operating costs.



WST.TE.HDTV SMPTE Cable Checker Set

### Application:

- Broadcast Infrastructure networks measurements
- SMPTE compatible HDTV system

### Features:

- Hybrid cables – fiber optic and Cu pairs checking
- LED quick signalization
- Automatic operation check of all fibers and wires
- Detects incorrect fiber and wire connection, disconnection and short circuit connection
- Built-in charger, battery status indicator

### Standard accessories:

- Carrying case
- Power charging adaptor
- USB Cable
- Manual
- Cleaning Instructions

### Options:

- LEMO connectors cleaning tool (DCS.F2.N02.PA)
- LEMO sleeve extraction tool (DCS.F2.035.PN)
- LEMO cleaning kit for F2 contact (WST.KI.125.34)

### Specifications:

Optical Light Source:		Note:	
Wavelength	1310 nm	typ. value	
Output power	-6.0 dBm	typ. value	
Optical Power Meter:			
Photodetector	1 mm InGaAs		
Working wavelengths	1310	can be customized	
Resolution	0.01		
Dynamic range	-40 dBm to +5 dBm		
General specifications:			
Dimensions	150 x 45 x 45 mm	measuring unit	without connectors
	65 x 45 x 45 mm	loop back	without connectors
	330 x 250 95 mm	case	
Weight	1.9 kg	Complete set with case	
Temperature	operating	-10 to +50 °C	
	storage	-40 to +70 °C	
Humidity (non-condensing)	0 to 95%		
IP rating	IP 54		
Battery working time	> 20 hrs		between battery charging

### Electrical wires checking:

- Electrical wires continuity
- Short circuit
- Isolation
- Electrical contacts – pins interconnection

### Quick LED check:

Green  
Orange  
Red

### OK

normal operational status

### Warning:

fiber out of limit, wires OK  
copper wires problem, fiber OK

### Failure: copper wires problem

IL of optical fiber is out limit

**Part number:**  
**WST.TE.HDTV**

SMPTE Hybrid Cable Checker Set



WST HYBRID CABLE CHECKER  
complete set with options



WST HYBRID CABLE CHECKER SMPTE main unit and loopback

**SMPTE cabling check:**

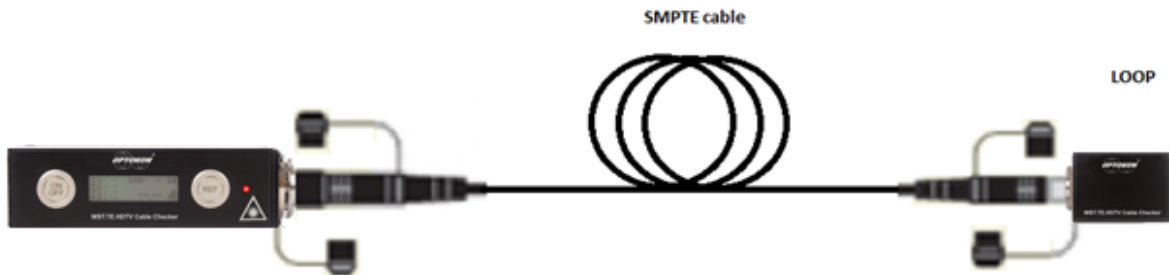

# OFT-850

## SMPTe Hybrid Cable Test Set

### Description:

The OFT-850 set consists of SMPTe SOURCE and SMPTe TESTER unit. The hybrid cable tester is designed for testing of loss in optical fibers and checking of continuity of copper pairs in hybrid cables. It combines optical light source on one side, optical power meter on other side and copper wires checker. It is ideal for testing large spaces of LEMO SMPTe Hybrid System for Broadcast Infrastructure Networks.

The ruggedized aluminium case makes the unit ideal for field operation. The memory capacity allows storage and uploading of more than 1000 measurements including cable number, result of metallic wires check and optical power value or insertion loss. The tester supports memory download and test report generating. The Lithium rechargeable battery ensures long term working with minimal operation costs.



SMPTe source

SMPTe tester

### OFT-850 set

### Features:

- Hybrid cables – fiber optic testing and copper pairs checking
- Ruggedized aluminium case
- MM or SM applications
- Simultaneous testing of 2 fibers
- Manual operation allows individual fiber or wire check
- Auto operation mode with optical loss pass/fail indication and „ALL OK, SHORT, PINOUT message for metallic wires check
- Able to detect incorrect fiber and wire connection, disconnection and short circuit connection
- Internal memory
- Displayed units: dBm, dB
- High dynamic range
- Built-in charger, battery status indicator
- Easy to use with menu navigation

### Specifications:

<b>Optical Light Source:</b>		
Output power		<b>Note:</b>
850 nm, 1300 nm	-26 dBm (62.5/125 µm fiber)	typ. value
1310, 1490, 1550, 1625 nm	-16 dBm	
Stability (1 hour, delta/2):		
850 nm, 1300 nm	± 0.03 dB	tested after 20 min warm up temperature 23 ± 1°
1310, 1490, 1550, 1625 nm	± 0.05 dB	
<b>Optical Power Meter:</b>		
Photodetector	1 mm InGaAs	
Working wavelengths	MM: 850, 1300 nm SM: 1310, 1490, 1550, 1625 nm	can be customized
Uncertainty	± 12%	1310, 1550 nm @ -20 dBm
Resolution	0.01	
Dynamic range	-60 dBm to +10 dBm -53 dBm to +17 dBm	1300, 1310, 1490, 1550, 1625 nm 850 nm

### Electrical wires checking:

Electrical wires continuity

Short circuit
Isolation
Electrical contacts –pins interconnection

**General specifications:**

Dimensions	145 x 145 x 56 mm	without connectors
Weight	400 g	with battery
Temperature operating	-10 to +50 °C	
Temperature storage	-40 to +70 °C	
Humidity (non condensing)	0 to 95%	
IP rating	IP 54	
Battery working time	> 20 hrs	between battery charging

**Ordering Code:**

**OFT-850** - **XX** - **XXXXX** - **XXX**

<b>M5 (MM)</b>	MM 50/125 µm	<b>Source wavelength</b> as below
<b>M6</b>	MM 62.5/125 µm	
<b>SM</b>	Single mode	

	<b>Connector type</b>
<b>3K93C</b>	SMPTE compatible HDTV connection system 3K.93C series
<b>other</b>	on request

light source code	Description <sup>1</sup>	application
<b>850</b>	850 nm	MM fiber testing
<b>30</b>	1300 nm	
<b>31</b>	1310 nm	SM fiber testing
<b>55</b>	1550 nm	
<b>62</b>	1625 nm	

Note: 1) other wavelengths on demand

**Standard accessories:**

- Power charging adaptor
- Carrying case
- USB Cable

**Options:**

- Reference patchcord

**Application:**

- Broadcast Infrastructure networks measurements
- SMPTE compatible HDTV system

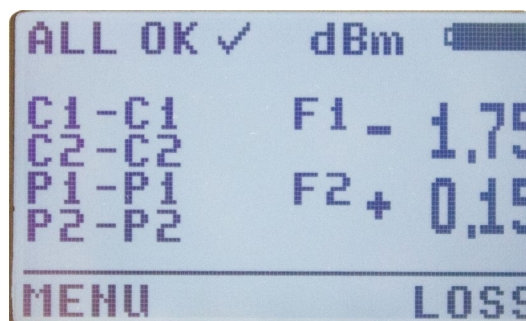

# LMC-01.GM

## Gigabit Micro Media Converter, Ruggedized type

### Description:

The LMC-01.GM offers the media converter housed in a metal box. It provides LEMO FXW 3K.93C connectors for fiber optic cable and copper twisted pairs ports for harsh environmental conditions. The LMC-01.GM 10/100/1000 Mbps adaptive Gigabit Ethernet media converter adopts switching technology to fulfill media conversion. It complies with IEEE802.3, IEEE802.3u, IEEE802.3z and IEEE802.3ab standards.

Presently it supports two types of media network connections: 10Base-T/100Base-TX/1000Base-T, and 100/1000Base-X, inter-converting electrical signals of 10Base-T/100Base-TX/1000Base-T twisted pairs with optical signals of 100/1000Base-SX/LX. It extends the transmission distance of network from 100 m via copper cable to 120 km via fiber optical cables. It supports transmission in multimode duplex fiber, single mode duplex fiber and single mode single fiber.

### Features:

- Rugged design for use in harsh environments
- Small compact box
- 10/100/1000BASE-T to 100/1000BASE-X converter
- FO interface: HMA Expanded Beam or LEMO FXW 3K.93C
- Full operation wavelength spectrum available
- Distance SM fiber up to 120 km
- UTP port: MRJ or multipin D38999 connector
- Support Jumbo Frame 9K Packet
- 5 to 15 V DC power supply



LMC-01.GM with LEMO SMPTE connector

### Specification:

Access mode	10/100/1000 Mbps Gigabit Ethernet
Standard	IEEE802.3 10Base-T Ethernet, IEEE802.3u 100Base-TX/FX Fast Ethernet, IEEE802.3ab 1000Base-T, IEEE802.3z 1000Base-SX/LX Gigabit Ethernet
Fiber Port	HMA-J Expanded Beam connector or LEMO FXW 3K.93C ferrule connector
UTP Interface	D38999/20WD18SN 18-pins connector2: data transmission & power supply or MRJ data transmission & USB power supply
Wavelength	MM: 1300 nm, SM: 1260 – 1630 nm
Transmission distance	UTP cable (10/100/1000Base-T): 100 m MM fiber optic cable, full duplex: 2 km SM fiber optic cable, full duplex: up to 120 km
LFP	Not Support
BER	<10 <sup>-9</sup>
MTBF	100,000 hours
LED indicator	PWR (Power supply) TX (LINK 100/1000, TP cable rate 100/1000M) FX/ACT (Optical link action /TP cable packet forwarding action)
Power supply	USB or DC 5 to 15 V
Environmental Temperature Humidity	According to ČOS 999905 (AECTP-300) Operating: -30°C to +50°C, Storage: -40°C to +70°C 10% to 95%
Mechanical	ČOS 999902 (AECTP-400, MIL-STD 810G), IP63 protection
EMC	ČOS 599902 (MIL-STD-461F)
Weight	290 g with LEMO connector 320 g with HMA connector
Dimensions (L x W x H)	150 x 45 x 45 mm case



LMC-01.GM with LEMO SMPTE connector



LMC-01.GM with HMA-J connector



LMC-01.GM with HMA-J connector

Ordering Code:

<b>LMC-01.GM</b>	-	<b>XX</b>	-	<b>XXX</b>	-	<b>XX<sup>2</sup></b>	-	<b>DC/P18<sup>3</sup> USB/MRJ<sup>4</sup></b>																														
<b>1G converter</b>		<table border="1"> <tr> <td colspan="2"><b>XX – Fiber Type</b></td> </tr> <tr> <td>M5:</td> <td>MM 50/125 μm</td> </tr> <tr> <td>M6:</td> <td>MM 62.5/125 μm</td> </tr> <tr> <td>S3:</td> <td>SM 9/125 μm, 1310<sup>5</sup> nm</td> </tr> <tr> <td>S5:</td> <td>SM 9/125 μm, 1550<sup>5</sup> nm</td> </tr> </table>	<b>XX – Fiber Type</b>		M5:	MM 50/125 μm	M6:	MM 62.5/125 μm	S3:	SM 9/125 μm, 1310 <sup>5</sup> nm	S5:	SM 9/125 μm, 1550 <sup>5</sup> nm		<table border="1"> <tr> <td colspan="2"><b>XX – Distance<sup>5</sup></b></td> </tr> <tr> <td>XX:</td> <td>MM</td> </tr> <tr> <td>10:</td> <td>10 km – SM</td> </tr> <tr> <td>30:</td> <td>30 km – SM</td> </tr> <tr> <td>50:</td> <td>50 km – SM</td> </tr> </table>	<b>XX – Distance<sup>5</sup></b>		XX:	MM	10:	10 km – SM	30:	30 km – SM	50:	50 km – SM		<table border="1"> <tr> <td colspan="2"><b>Power Supply</b></td> </tr> <tr> <td>DC:</td> <td>5 - 15 V DC</td> </tr> <tr> <td>USB:</td> <td>USB</td> </tr> <tr> <td colspan="2"><b>UTP port</b></td> </tr> <tr> <td>MRJ:</td> <td>MRJ – RJ-45 connector</td> </tr> <tr> <td>P18:</td> <td>D38999 multipin connector</td> </tr> </table>	<b>Power Supply</b>		DC:	5 - 15 V DC	USB:	USB	<b>UTP port</b>		MRJ:	MRJ – RJ-45 connector	P18:	D38999 multipin connector
<b>XX – Fiber Type</b>																																						
M5:	MM 50/125 μm																																					
M6:	MM 62.5/125 μm																																					
S3:	SM 9/125 μm, 1310 <sup>5</sup> nm																																					
S5:	SM 9/125 μm, 1550 <sup>5</sup> nm																																					
<b>XX – Distance<sup>5</sup></b>																																						
XX:	MM																																					
10:	10 km – SM																																					
30:	30 km – SM																																					
50:	50 km – SM																																					
<b>Power Supply</b>																																						
DC:	5 - 15 V DC																																					
USB:	USB																																					
<b>UTP port</b>																																						
MRJ:	MRJ – RJ-45 connector																																					
P18:	D38999 multipin connector																																					
		<table border="1"> <tr> <td colspan="2"><b>XXX – Connector type<sup>1</sup></b></td> </tr> <tr> <td>HMA</td> <td>HMA-J expanded beam connector</td> </tr> <tr> <td>FXW</td> <td>LEMO FXW 3K.93C</td> </tr> <tr> <td>FCON</td> <td>Ferrule rugged connector</td> </tr> <tr> <td>HE</td> <td>HE-IP67 connector</td> </tr> <tr> <td>DM4-38</td> <td>Diamond MIL 38999 FO connector</td> </tr> <tr> <td>DM4-83</td> <td>Diamond MIL 83526 FO connector</td> </tr> </table>		<b>XXX – Connector type<sup>1</sup></b>		HMA	HMA-J expanded beam connector	FXW	LEMO FXW 3K.93C	FCON	Ferrule rugged connector	HE	HE-IP67 connector	DM4-38	Diamond MIL 38999 FO connector	DM4-83	Diamond MIL 83526 FO connector																					
<b>XXX – Connector type<sup>1</sup></b>																																						
HMA	HMA-J expanded beam connector																																					
FXW	LEMO FXW 3K.93C																																					
FCON	Ferrule rugged connector																																					
HE	HE-IP67 connector																																					
DM4-38	Diamond MIL 38999 FO connector																																					
DM4-83	Diamond MIL 83526 FO connector																																					

- Note:
- 1) FO interface: other connector on request
  - 2) MM fiber – the distance depends on fiber type, up to 2 km, SM fiber – longer distance on request
  - 3) P18: LAN and power supply in one 18-pins connector
  - 4) MRJ: LAN RJ-45, power supply – USB
  - 5) Other SM wavelengths and distance on request
  - 6) Appropriate cables available on request